

# 15 WX

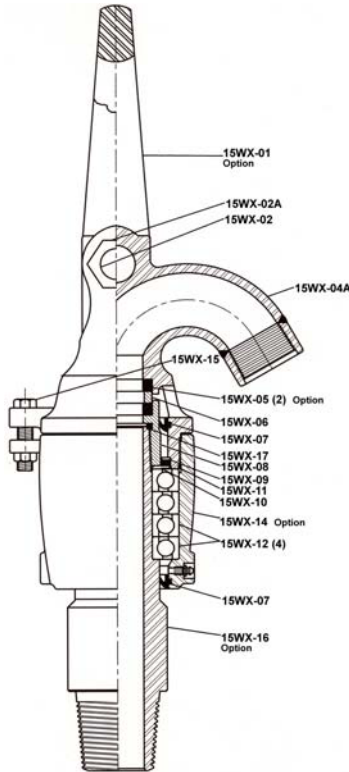

- For WATER, GEOPHYSICAL, and MONITORING well drilling
- Light Weight
- Alloy Steel construction for strength
- Large Watercourse
- For Pulldown or Kelly Bar machines
- Flexible BAIL or ELEVATOR SHANK available
- Thrust ball bearings support drill pipe load while providing radial capacity.
- Seal Bearing Case with grease lubrication
- TRUNNION PINS available
- Choice of lower connection threads
- Designed for easy field service and maintenance

### TECHNICAL DATA

MODEL #	LENGTH	WT/LBS EACH	HOSE CONN. FEMALE	LOWER CONN* PIN	WATER COURSE	WORKING PRESSURE	BAIL OPENING
15WX	33"	95	2" NPT	2-7/8" OD 8-V LH	2" ID	To 300 PSI	3-3/4" X 8"

### SAFE WEIGHT LOADS

MODEL #	STATIC LOAD	ROTATING LOAD	SAFE DEPTH			
			2-3/8", 6.65	2-7/8", 10.4	3-1/2", 13.3	4-1/2", 16.6
15WX	50,000 LBS.	27,000 LBS. @ 100 RPM	2,700 FT	1,800 FT	----	----

### PARTS LIST

PART NO.	DESCRIPTION	WT/LBS	QTY. REQ.	PRICE
<b>15WX-3010-XX</b>	WESTERN SWIVEL, LESS BAIL, 2" NPT FEMALE HOSE CONNECTION AND 2 7/8" OD 8-V LEFT HAND PIN LOWER CONNECTION			2826.96
	ADD FOR BAIL			414.64
	ADD FOR SPECIAL LOWER CONNECTION			275.00
	ADD FOR TRUNNION PIN			280.00
15WX-01	BAIL	16.00	1	414.64
15WX-02	BAIL PIN	3.00	1	234.48
15WX-02A	BAIL PIN NUT	.50	2	6.67 ea
15WX-04A	GOOSENECK, 2" NPT FEMALE HOSE CONNECTION	28.00	1	1005.51
15WX-05	+ PACKING	.25	2	13.88 ea
15WX-05-90	PACKING, 90 DURO HIGH PRESSURE	.25	Option	13.88 ea
15WX-05V	PACKING, VITON	.25	Option	42.56 ea
15WX-06	+ WEARBUSHING	.50	1	46.90
15WX-07	+ HOUSING SEALS	.12	2	23.01 ea
15WX-07V	HOUSING SEALS, VITON	.12	Option	54.77 ea
15WX-08	SPINDLE NUT	3.50	1	277.31
15WX-09	+ SHIELD SEAL	.25	1	41.55
15WX-10	+ BEARING SHIELD	.37	1	58.55
15WX-11	BEARING RETAINER WIRE	.12	1	9.13
15WX-12	+ BEARINGS, DOWNTHRUST/UPTHRUST	5.00	4	153.85 ea
15WX-14	BEARING HOUSING	16.00	1	840.78
15WX-14A	BEARING HOUSING, WITH (2) TRUNNION PINS	24.00	Option	1120.78
15WX-15	LOCK SCREW AND NUT, BEARING HOUSING	.25	1	7.84
15WX-16GD-LP	SPINDLE, 2 7/8" OD 8-V LH PIN	15.00	1	694.39
15WX-16GE-LP	SPINDLE, 2 7/8" IF LH PIN	15.00	Option	969.34
15WX-17	+ SPINDLE THREAD SEAL	.06	1	12.78
15WX-40	MAINTENANCE KIT (8) 15WX-05, (1) 15WX-06			150.04
15WX-40R	REPAIR KIT + Included in Repair Kit			806.51

Other sizes of connections available, please consult factory.

Option for above swivel, may affect pricing of complete swivel. Other options available, please consult factory.

