

20 WXA

Adjustable Packing Swivel

- For WATER, GEOPHYSICAL, and MONITORING well drilling
- Light Weight
- Alloy Steel construction for strength
- Large Watercourse
- For Pulldown or Kelly Bar machines
- Flexible BAIL or ELEVATOR SHANK available
- Thrust ball bearings support drill pipe load while providing radial capacity.
- Seal Bearing Case with grease lubrication
- TRUNNION PINS available
- Choice of lower connection threads
- Designed for easy field service and maintenance

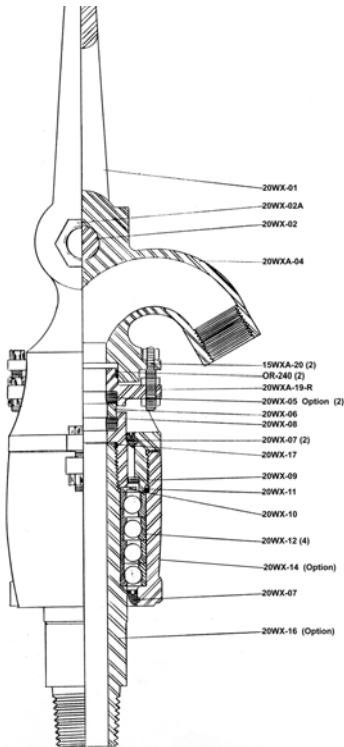

TECHNICAL DATA

MODEL #	LENGTH OVERALL	WT/LBS EACH	HOSE CONN. FEMALE	LOWER CONN* PIN	WATER COURSE	WORKING OPENING	BAIL OPENING
20WXA	38"	165	2-1/2" NPT	3-1/2" OD 8-V LH	MAX 2-1/2" ID	To 300 PSI	4-1/4" X 8"

SAFE WEIGHT LOADS

MODEL #	STATIC LOAD	ROTATING LOAD	SAFE DEPTH			
			2-3/8", 6.65 3,600 FT	2-7/8", 10.4 2,400 FT	3-1/2", 13.3 1,800 FT	4-1/2", 16.6 ----
20WXA	70,000 LBS.	36,000 LBS. @ 100 RPM				

PARTS LIST

PART NUMBER	DESCRIPTION	WT/LB EACH	QTY. REQ.	PRICE
20WXA-3120-XX	WESTERN SWIVEL, LESS BAIL, 2 1/2" NPT FEMALE HOSE CONNECTION, WITH ADJUSTABLE PACKING, WITH 3 1/2" OD 8-V / 3 1/2" IF LH PIN LOWER CONNECTION			3911.12
	ADD FOR BAIL			519.88
	ADD FOR "SPECIAL SPINDLE"			275.00
	ADD FOR TRUNNION PINS			280.00
20WX-01	BAIL	21.00	1	519.88
20WX-01E	ELEVATOR SHANK	42.00	OPTION**	1645.53
20WX-02	BAIL PIN	4.00	1	271.05
20WX-02A	BAIL PIN NUT	.75	2	10.92 ea
20WXA-04A	GOOSENECK, 2 1/2" NPT FEMALE	58.00	1	1339.19
20WX-05	+ PACKING	.25	2	15.34 ea
20WX-05-90	PACKING, 90 DURO (RED)	.25	OPTION	15.34 ea
20WX-05V	PACKING, VITON	.25	OPTION	42.56 ea
20WX-06	+ WEARBUSHING	1.00	1	46.90
20WX-07	+ HOUSING SEAL	.12	2	24.16 ea
20WX-07V	HOUSING SEAL, VITON	.12	OPTION	59.53 ea
20WX-08	SPINDLE NUT	4.50	1	316.38
20WX-09	+ SHIELD SEAL	.37	1	41.55
20WX-10	+ BEARING SHIELD	.50	1	60.09
20WX-11	BEARING RETAINER WIRE	.12	1	10.36
20WX-12	+ BEARINGS	4.25	4	197.90 ea
20WX-14	BEARING HOUSING	37.00	1	1166.00
20WIR-14A	BEARING HOUSING, 7 1/2" SHOULDERS 2" PIN TRUNNION PINS	43.00	OPTION	1446.00
20WIR-14B	BEARING HOUSING, 8 5/16" SHOULDERS 2" PIN TRUNNION PINS	45.00	OPTION	1446.00
15WX-15	LOCK SCREW WITH NUT, BEARING HOUSING	.25	1	7.84
20WX-16JD-LP	SPINDLE, 3 1/2" OD 8-V LH PIN	28.00	1	989.13
20WX-16JE-LP	SPINDLE, 3 1/2" IF LH PIN	34.00	OPTION**	989.13
20WX-16GE-LP	SPINDLE, 2 7/8" IF LH PIN	31.00	OPTION**	1264.13
20WX-17	+ SPINDLE THREAD SEAL	.06	1	18.48
20WXA-19-R	PACKING ADJUSTING GLAND	7.25	1	310.32
15WXA-20	ADJUSTING SCREW W/NUTS	1.75	2	29.12 ea
OR-240	+ O-RING, ADJUSTING GLAND	.01	2	4.00 ea
20WX-40	MAINTENANCE KIT (8) 20WX-05, (1) 20WX-06			161.14
20WXA-40R	REPAIR KIT, + INCLUDED IN REPAIR KIT			993.34

Other sizes of connections available, please consult factory.

Option for above swivel, may affect pricing of complete swivel. Other options available, please consult factory.

